

M 2706 MEC

BOSTON & MAINE RAILROAD
HISTORICAL SOCIETY
ARCHIVES

81,0006

Spring 1980

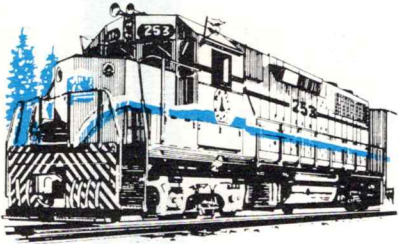

MAINE CENTRAL

MESSENGER



MESSENGER

The Maine Central MESSENGER is published at Portland, Maine by Maine Central Railroad Company and Portland Terminal Company. It is circulated without charge to active and retired employees of these companies and to customers and other friends throughout the nation. Printed in Maine on Maine-made paper.



EDITOR

Bradley L. Peters,
Vice President

MANAGING EDITOR

Joseph H. Cobb

ASSISTANT EDITORS

Barbara Spaulding	Eastern Subdivision
Albert Wetmore	Rigby
Wendell Lewis	Rockland
David Smith	Waterville Shops
Lucette Huard	Waterville Station
Arthur Doucette	Waterville Yard
Eleanor True	General Offices
Connie Davis	General Offices
Alice Foley	General Offices
Sonia Duplessie	General Offices
Geoffrey Doughty	General Offices
Craig Wilson	Sports
Mary Morse	Retirees
Athie Bryant	Retirees and Washington County

CONTENTS

Baseball and Opportunity.....	3
Of Paper Mills and Railroads.....	3
Storing Up Maine Central Scenes.....	4
Hugh Chisholm's Rumford.....	5
What's New at the Shops.....	6
Waterville Shops' Impact Grows.....	7
Here's U.S. Patent No. 1.....	8
Maine's Railroad Historian.....	9
News Briefs.....	11
The Grapevine.....	13
Railroad Safety.....	20

The Cover



Not from ours or from any real railroad, this scene is from the mind, hand and pen of Ken White, former commercial artist, now a Maine Central locomotive engineer.

U. S. Filter Buys 36 Percent of Maine Central Common Stock

United States Filter Corporation, an international organization whose divisions and companies market dozens of products and services, acquired a total of 48,299 shares of Maine Central's common stock late in March. In early April the Company acquired 2,000 additional shares.

The block of Maine Central stock — approximately 36 percent of the railroad's common — was owned previously by Amoskeag Company. For several years Amoskeag sought to gain control of Maine Central, but the railroad successfully opposed such efforts.

U.S. Filter's Chairman and President, Raymond A. Rich, met with Chairman E. Spencer Miller and President John F. Gerity of Maine Central in Portland April 1. The leaders of the two companies had a harmonious meeting which produced a mutual policy of complete cooperation in the direction of a more prosperous and efficient Maine Central which will be to the benefit of Maine Central's other shareholders, its customers and employees.

U.S. Filter had sales of \$612 million last year and net income of nearly \$22.5 million. It produces a wide range of engineering services, manufactures air and water pollution control equipment and provides chemicals for water treatment and purification. Through its divisions and subsidiary companies, U.S. Filter is involved in power generation, energy technology, natural resources, environmental systems, specialty chemicals and investments. Companies within the organization, incorporated in Delaware in 1957, include the United States Riley Corporation, the Resource Science Corporation, Williams Brothers Engineering Company, Filtrol Corporation, Drew Chemical Corporation, the Koehring Company and many others in the U.S., Canada and abroad.

U.S. Filter's corporate offices are in New York City.

In This Issue

A young commercial artist from Detroit has realized his life-long ambition to become a locomotive engineer, but still draws and paints as a hobby.

Page 4

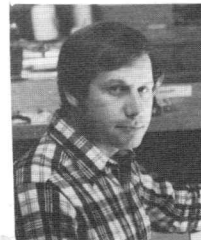

Gary Guimond of Boise Cascade takes us on a tour of the former Oxford mill at Rumford, where a \$254 million expansion is nearing completion.

Page 5

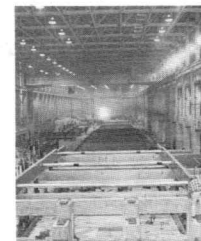

A words-and-pictures account of the changes and the new equipment at the Waterville Shops, now assuming a new and larger role for Maine Central and other industries.

Page 6

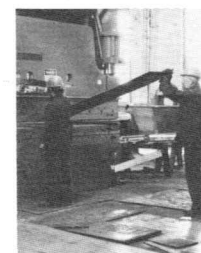

in our opinion. . .

Baseball and Opportunity in Capitalist America

by E. Spencer Miller, Chairman, Maine Central Railroad

Yesterday I had a communication from a self-described liberal young lady, sometime graduate of one of the "Seven Sisters", and now full of activism and political ambition. She took me to task for opposition to our welfare program, was disagreeable enough to imply that my education must have been largely that of an exposure to the fairy-tales of Horatio Alger and doubted that I could actually document even one case of a poor boy who sold newspapers on trains and then rose to be a captain of industry. The latter seemed a reference to a decade old editorial in the Messenger.

It is a pleasure to meet the challenge, but before stooping to pick up this daintily barbed little gauntlet I should like to beguile you with a baseball story.

In 1905 the 20 year old Edward Victor (Knuckles) Cicotte went south for spring training with the Detroit Tigers. Eddie proudly traced his ancestry back to a French soldier who had come to Michigan with Cadillac at the end of the 17th century. A few of us old-time baseball students recall how Eddie went on to be a star with the Red Sox and a super-star with the White Sox and how his "riser", "downer", "emery ball", and various other legal and illegal deliveries, set him apart in a class of his own. In 1905 these potentialities were undiscovered and when the Tigers journeyed north Eddie was left to toil at Macon.

Detroit led by the peerless "Wahoo Sam" Crawford had pennant ambitions but by August was in trouble, and far behind Connie Mack's Athletics starring the generally un-

hittable Rube Waddell. One day Eddie received a wire ordering his return and asking that he try to bring with him a lefthanded pitcher and a hardhitting outfielder. Shortly thereafter three young ball players arrived in the Motor City. The pitcher's name was George Napoleon "Nap" Rucker who went over to Brooklyn and pitched there for the next decade. The 19 year old hardhitting outfielder was a fair choice, too. His name was Tyrus Raymond Cobb.

When I came to Maine in 1940 her first citizen was undeniably Hugh J. Chisholm, Esq., domiciled on Portland's Western Promenade. Mr. Chisholm dominated Oxford Paper Co. and was most influential in the affairs of Maine Central, being its senior director, largest shareholder and owner of a substantial quantity of the railroad's debt.

Mr. Chisholm's father "discovered" Rumford and was immediately impressed with the potential for industrial development presented by the great falls in the Androscoggin with a mean flow of 2500 cubic feet per second. He founded International Paper Co., became its first President and later organized Oxford.

Mr. Chisholm senior came to Detroit from Ontario as a penniless young man but soon secured a position selling newspapers, chewing gum and candy bars on the Grand Trunk train running between Detroit and Grand Rapids. Another young news butcher who worked that same train was "some pumpkins", too. His name was Thomas Alva Edison.

Of Paper Mills and Railroads

It's difficult to mark the beginning or the end of the current era of remarkable growth experienced in the pulp and paper industry of Maine, but so far the investment has exceeded \$1 billion and another \$1 billion is scheduled over the next few years. The benefit to the state's economy and society as a whole are incalculable. There are and will be products worth more money, more jobs and a more efficient involvement by the industry in the affairs, progress and quality of life in the Maine communities where the mills are located.

This huge expenditure by the pulp and paper industry has expanded and modernized production facilities, established dimension lumber and woodchip mills, converted steam plants from use of oil to bark and waste wood, and built pollution abatement facilities to help the towns and the state clean up Maine's water and air.

Of direct interest to the transportation industry is the fact that this investment is expected to significantly boost daily paper production. A comparable increase will be required in the transport of pulpwood, woodpulp and chemicals, and with the additional tons of finished products, the task looms large for Maine Central.

A total of 17 pulp and paper mills, from the largest to the smallest, are located in communities served by Maine Central. They are in Westbrook, Lisbon Falls, Augusta, Old Town, Bucksport, Skowhegan, Madison, Topsham, Jay, Livermore Falls, Gardiner, Rumford, Brewer, Woodland, Waterville, Winslow, and Lincoln.

Maine Central moves most of the paper production, and

added to raw materials for the industry this amounts to about 60 per cent of all Maine Central carloads. As a vital link in the production chain, moving raw materials to the plant and products to market is Maine Central's single most important daily responsibility.

Development and retention of this traffic has required huge railroad investments too — in locomotives, specially-equipped boxcars, chip gondolas, pulpwood cars, sidings, loading tracks, yards, and even full-time switching operations. These investments, and many more, constitute the railroad's stake in the pulp and paper industry's commitment to Maine. They represent our assurance of transportation support and our contribution to the success of the biggest industrial expansion this state ever has seen.

Here are some of the projects now underway and their price tags:

- Georgia-Pacific, Woodland...\$30 million to build and equip Maine's first wafer-board mill and to rebuild a paper machine.
- International Paper, Jay.....\$71 million to convert a machine to production of light, coated publication paper.
- Madison Paper, Madison.....\$185 million to expand and modernize the mill increasing production by five times.
- Boise Cascade, Rumford.....\$254 million for a new paper machine, largest of its kind in the world; a new recovery boiler, a new building and associated improvements.

Of Paper Mills . . . to Page 10

storing up maine central scenes

For a young man, Ken White has covered a lot of ground.

He was British, originally, then Canadian, now American. He was a commercial artist, for a while, then a soldier, and now a locomotive engineer.

Not quite 35, he operates main line trains between Rigby and Bangor. It's his lifelong ambition, and he'll stick with it, he says, while he continues art as a hobby. Like many another veteran of Viet Nam, he's trying to forget the soldiering.

Ken White is in Maine because he wants to be, and because Maine "is everything Detroit wasn't."

He was born in England, but grew

up in Toronto, near the Canadian National, and developed a keen interest in trains, locomotives and cars. They turned out to be his favorite subjects for drawings, later on, and he drew trains and engines when he was being paid to draw automobiles in a Detroit advertising art studio. "I had to draw cars like somebody else wanted me to," Ken says, "but I could draw railroad scenes to my own liking."

Ken's railroad hobby led him to buy a ticket on a steam excursion trip run by the CP in the fifties, and he went aboard a coach and claimed a rear-facing seat opposite somebody's knapsack and a small suitcase. He was sitting there, waiting for the trip to

start, when the owners appeared. They claimed both seats, at first, then reconsidered, inviting Ken to remain where he was and join them.

One was Stew Park, now Maine Central chief mechanical officer, then a student at the University of Pennsylvania. It was the beginning of a friendship that has lasted ever since.

Before the war in Southeast Asia, their mutual interest in railroads kept Stew and Ken in touch, and they swapped data and railroad pictures as Stew joined Maine Central and as Ken worked as an artist in Detroit. At Stew's invitation, Ken visited Maine, and after his stretch in Viet Nam, he came to stay. "It was clean, green and quiet," Ken says, "everything Detroit wasn't."

He had applied for a job with Maine Central, "one of a long list," he says, recalling the "don't-call-us" advice they all received. But in a short time, the office called Ken, and he went to work as a brakeman. He was selected, after two years, to train as an engineer. Ed Peterson, now assistant road foreman, was a classmate, and they learned their new craft under the capable tutelage of Larry Hibbard and the late Leon Peasley.

Ken and the others were broken in gradually, working first as hostlers, then on switchers in yard service, and finally on the road. The memory of Ken's first road trip is vivid. "Up the Mountain and back," he says, "with five units and no trouble, but plenty of worry. The older men always made it look easy, and I'd been along many times as brakeman, but it was a little different when it was all up to me."

After nine years of it, Ken still has no fears, and if anything, enjoys his job more and more. "I'd better," he says, "because if I didn't, I would have wasted a lot of wishing."

And now, from his right-side window in the lead engine, Ken is storing up Maine Central scenes in his mind . . . scenes that he later transforms into crisp line drawings at his Pownal home-studio. Making them is a hobby now, and later on, for Ken and many another Maine Central Railroader, they'll be the fuel for memories.

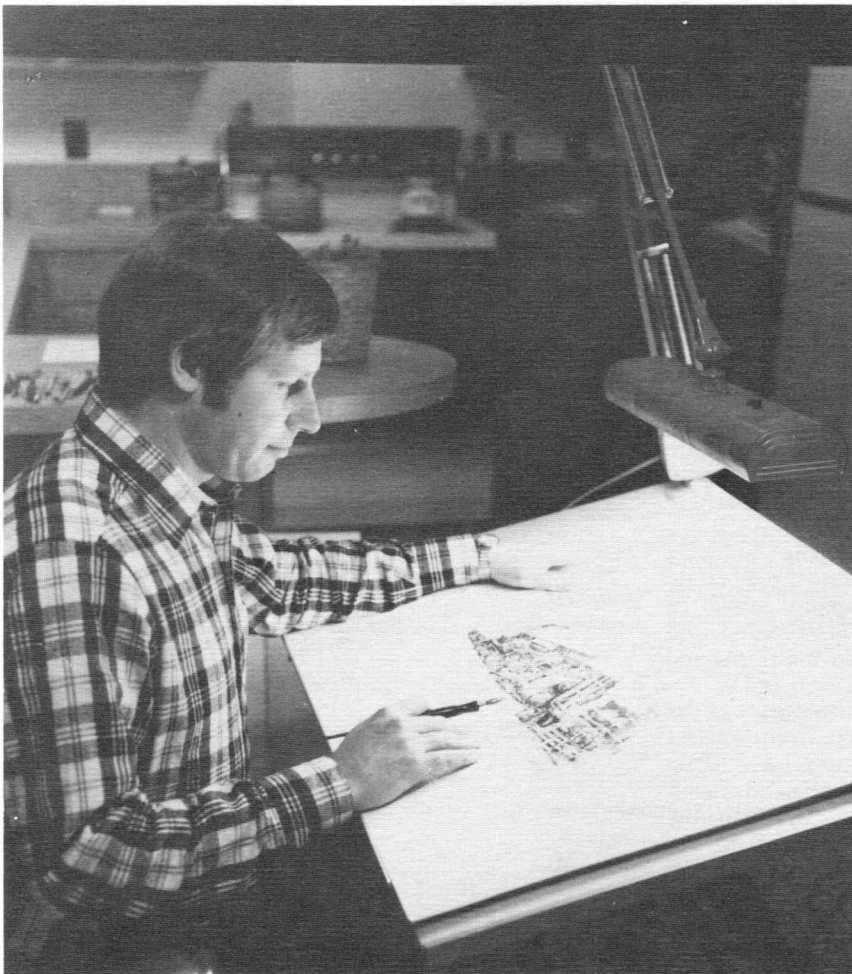

Ken White, Maine Central locomotive engineer, works on a pen-and-ink drawing in his Pownal home.

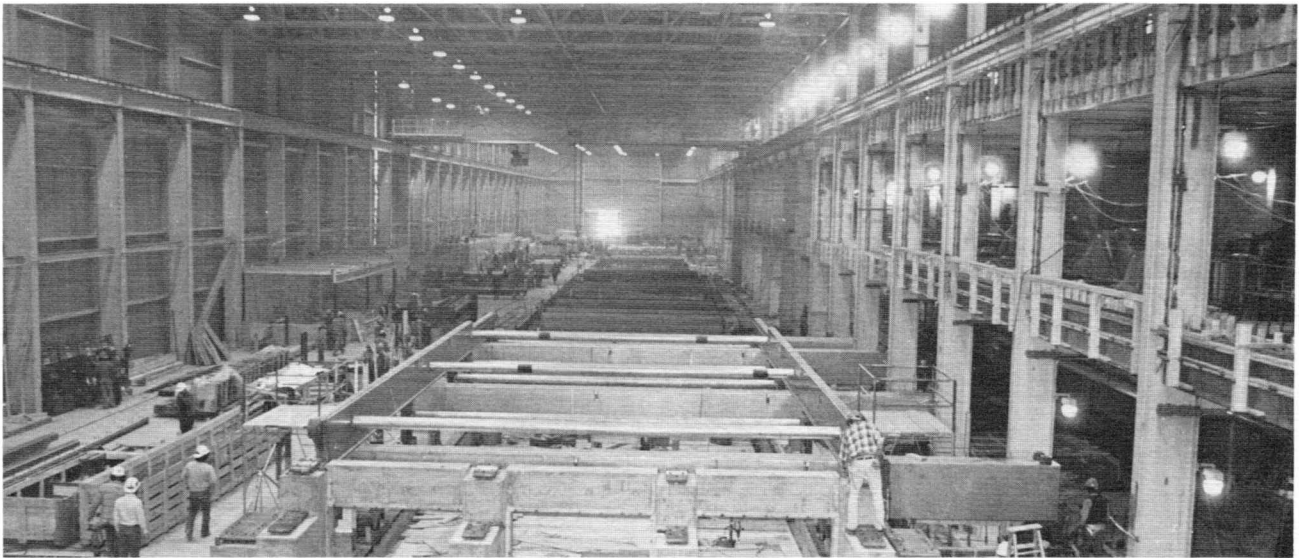

A view of the new paper machine room at Boise Cascade, Rumford. The Fourdrinier framework is being assembled in place in the foreground. Dryer cans and other dryer section equipment is being positioned beyond the Fourdrinier.

hugh chisholm's rumford and boise cascade

Hugh Chisholm, Sr., would have been proud of us!

True, he might have blinked his eyes a few times and scratched his head before he could grasp the magnitude of what Boise Cascade is doing in Rumford, but no doubt he would have approved.

Chisholm, who built the original mill, Oxford Paper Company, (and the town of Rumford, for that matter) lived in a simpler time.

But he certainly knew that every manufacturer must constantly assess the market for his product, determine how best to penetrate it and maintain an economical and profitable foothold in that market. He also knew that when the time is right, when the market and other conditions demand it, a decision to expand and modernize must be considered. This was true in Chisholm's 19th century America, and, of course, is still true today.

For Boise Cascade, having purchased the mill from Ethyl Corporation in 1976, the time for decision was over in 1978. In August, that year, the company announced the largest capital expansion in its history — and it was set to occur in Rumford. Ray Taylor, manager of manufacturing at the Rumford mill, told a group of service award employees that a key factor in Boise Cascade's decision to expand and modernize in Rumford was the high quality of the work force here. There are trees and water in other locations, he said, but the professional attitude of the 1,700 employees in our Rumford mill is of

the highest quality. And so Boise, along with Governor James B. Longley, announced the \$254 million expansion in Rumford. The expansion which should be completed in early 1981, will include a machine for the manufacture of light coated publication grade paper, a recovery boiler and thermo-mechanical pulp facility.

Current production of the mill includes hardwood and softwood pulp, heavy coated publication papers (the mill makes paper for National Geographic, TV Guide, People, Cosmopolitan, Seventeen and many other well-known magazines). Other papers produced include envelope, forms bond, offset book.

The new No. 15 Paper Machine will increase local production by about 40 percent and produce a light coated publication grade paper. The width of the machine is 314 inches and it will produce paper at about 50 miles per hour, a truly high-speed machine. The building the machine will be housed in is over 700 feet long, over 200 feet wide and 75 feet high.

The expansion includes a high technology odor-reducing recovery boiler to recycle chemicals used in the cooking/digesting of the wood chips and a thermo-mechanical pulp facility which will produce the high quality raw stock needed for the new paper machine.

The actual construction of the pro-

by Gary Guimond

ject began in February 1979 after the old Maine Coated site was cleared for the location of the new paper machine.

Two of the most important aspects of the whole mill operation, of course, are getting the materials needed for production into the mill and getting the finished product to market. Projections on these two steps in our operation indicate some interesting figures. For example, additional quantities in the following materials are projected: over 700 more carloads of clay a year, over 120 carloads of starch a year and over 250 cars of oil a year. On the other end of things, Boise will need about 170 additional rail cars a year to ship increased production to national markets.

Obviously, close coordination between Boise Cascade and Maine Central Railroad will make the additional traffic picture as smooth as possible.

The world has turned over many times since Hugh Chisholm first viewed the falls along the Androscoggin River and decided to build a paper mill and a town called Rumford. Even so, we know he would understand and appreciate the expansion and modernization of his old mill into one of the best papermaking facilities in the United States.

what's new at the shops

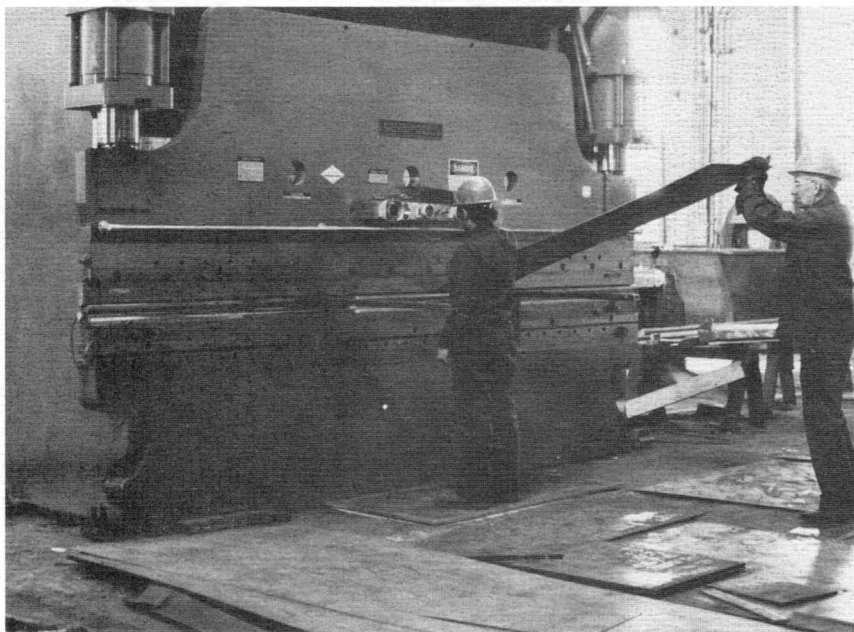
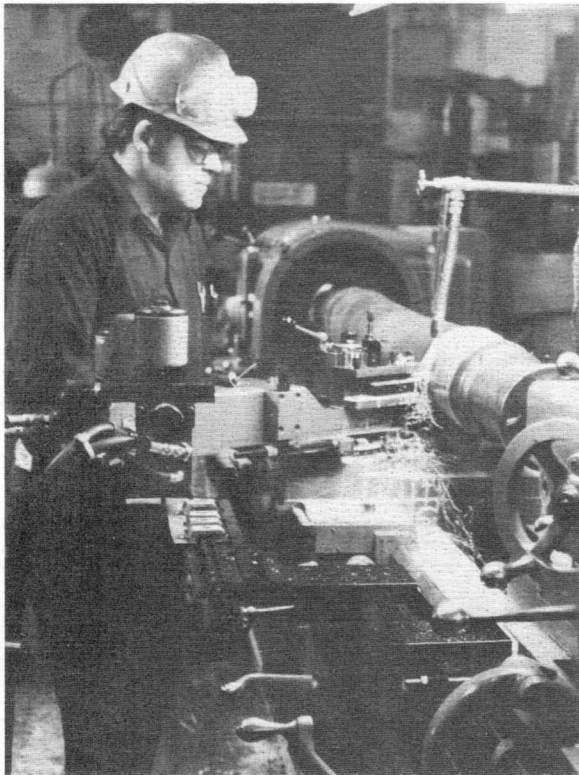

Some of the new equipment that's helping do jobs better and faster at Waterville Shops. Top left and clockwise, Bill Trafton operates the new lathe in the Wheel Shop. Harold Bear drives the mobile crane, and Carl Fletcher works with Clarence Pomeroy on the repair track. Lower left, the Cincinnati press brake helps Larry Kitchen and Carl Fisher with a metal-forming task.

Waterville shops' impact grows

New equipment at Waterville Shops — huge, heavy and expensive metal-working machines that cut and shape and finish to minute tolerances — is giving the railroad facility new capabilities. At the same time, this equipment is broadening the role and increasing the impact of the Shops as a resource for other Maine industries.

The Shops are doing more these days for Maine Central, Chief Mechanical Officer Stewart Park said recently, "and we're doing a lot more for the paper mills, other plants around the state and other railroads, some from distant places."

And Park added quickly that it's not just the new machinery, but the resourceful railroad people at Waterville. "It's happened time and time again," he said. "We justify the purchase of a new piece of equipment by citing safety, economy and increased production. Then, when it's installed, we soon discover that the Shops' management and employees have it doing much more than we anticipated, gaining far greater use and advantage than we had cited as justification for the purchase."

Park was referring to the new axle lathe and hydraulic wheel press in the wheel shop, the metal-forming press brake, the plate shear, the improvements brought to the repair track by the new "Skid Steer" loader, portable crane, the horse trailer packed with equipment and ready for re-railing cars, and other improvements. Some are new and cost tens of thousands, others are the results of lots of ingenuity, but all help the Shops do a better job.

In past years, some of the jobs now being done at Waterville were done by someone else, somewhere else, at much greater cost.

This is especially true, Park said, about the big metal-forming machines . . . the shear and the press brake. Such high capacity equipment is available nowhere else in Maine except at the Bath Iron Works shipyards. Before these machines were installed, Shops workers depended on metal-forming devices they had inherited from the days of wooden cars and steam locomotives. They could cut and bend some shapes, but were limited, and couldn't handle large jobs effectively.

"We had to 'farm out' the center fillers we use to convert pulpwood cars to accommodate eight-foot logs," Park said. Now, with the shear and the press brake, "we can do it at Waterville. It's fast and safe, and we can make doors and other components that had to be contracted before."

The big new axle lathe in the wheel shop is capable, Park says, of taking a whisker-sized cut from a chunk of steel in order to meet strict A.A.R. tolerances. It's helping the wheel shop stay ahead of the increasing volume of work brought about by the general use today of roller bearings. Park said lateral play of the wheels limited by the roller bearings increases wear of the wheel flanges, and wheelsets have to be changed more frequently as a result, making more work for the new lathe. The hydraulic wheel press speeds up the process of mounting and dismounting wheels, provides better control, (fine-tuning, Park calls it) and improves safety.

The new lathe and press, in combination, gives the wheel shop the efficiency it needs to keep up with our company's demands, Park says, but also to handle wheel and axle machin-

ing operations for the Sperry Rail Detection cars and several other New England railroads.

Much less dramatic, but an important improvement, is the mobile crane on the car repair track, which is used to handle doors, drawbars and other heavy loads, including wheelsets. The Shops had three small, mobile cranes that dated from the 30's with tiny, hard-rubber wheels. The new 6 ton crane replaces them, Park says, and does a number of additional jobs, too.

The "Skid Steer" loader, which handles a long list of material-moving tasks and which has almost completely eliminated hand-and-shovel snow removal work on the repair track, is another hard-working piece of equipment recruited at the Shops in recent months. "We bought the first one," Park says, "to use in the grit blast room, but it wasn't there long before several people claimed it for work on other jobs."

That's the way it is at Waterville Shops, a slightly old, slightly gray set of buildings that are dark from the smoke of steam engines, but more than ever a vital, working part of today's Maine Central.

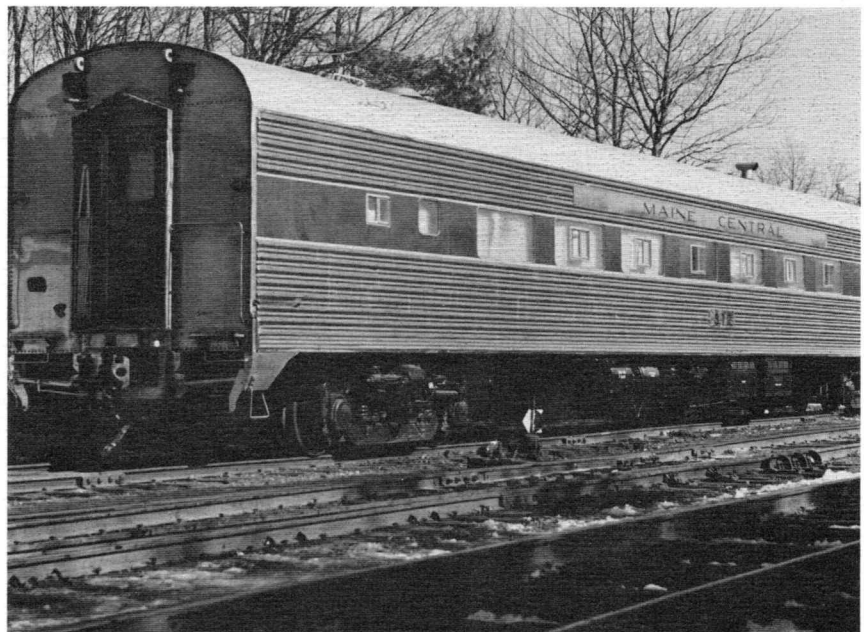

Maine Central's new work car 970 was spotted at Brunswick by photographer Ron Johnson. The unit was the first of several to be converted at Waterville Shops from ex-AMTRAK coaches. The car has complete facilities for crew comfort including electric lights and a furnace.

In the 1830's, when Maine was only ten years old, one of its brightest political stars was John Ruggles, a young Thomaston lawyer. He made his mark, as they used to say, before he was forty. He was a seven-year State Representative, Speaker of the House and a Justice of the Maine Supreme Court. He was appointed to the U. S. Senate, introduced and promoted the legislation to establish the Patent Office, registered the first patent, returned to Thomaston, and disappeared — at least as far as the records reveal — into the fogs of the Georges River.

That's about it for John Ruggles, except that his patent — Number One, dated July 13, 1836 — was for "traction wheels for locomotive steam engines for rail and other roads." So he's fair game for the MESSENGER, even if we never find that the "traction wheels" worked, or never learn whatever else became of John Ruggles.

John Ruggles' state service came to an end with his appointment to the U. S. Senate in 1834. In December of 1835 he submitted a motion for the

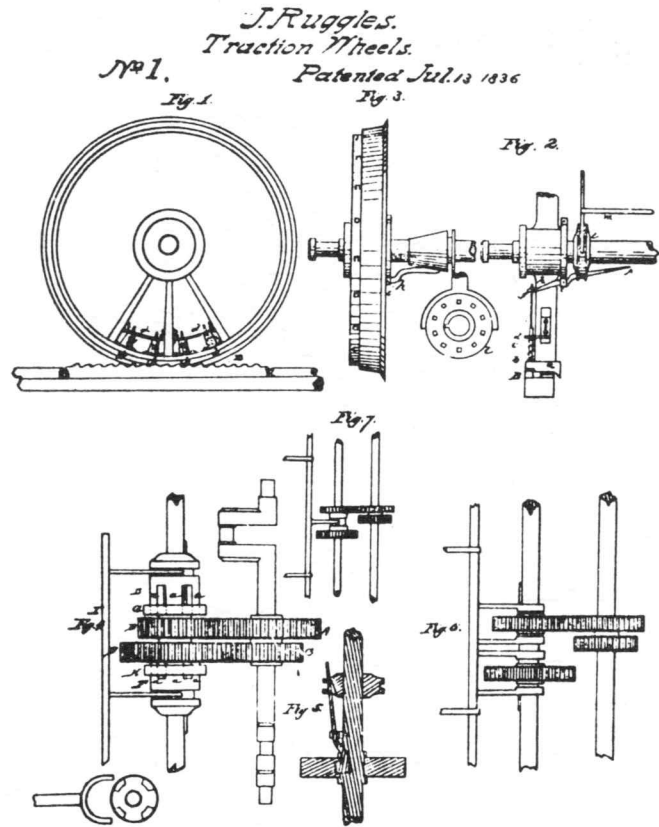

Drawings that accompanied the text of U.S. Patent No. 1, issued to Senator John Ruggles of Thomaston, Maine, in 1836. These diagrams show his idea of "traction wheels" with "retreating cogs" that were designed to engage slots in a check rail and develop traction for steam locomotives.

here's

u.s. patent no. 1

appointment of a committee "to take into consideration the state and condition of the Patent Office," and on April 28, in his capacity as chairman, reported the bill. It passed the Senate June 29, the House on July 2, and received the signature of President Martin VanBuren on July 4, 1836.



Sen. John Ruggles of Maine

Nine days later, on July 13, John Ruggles was granted Patent Number One for his "traction wheels" idea.

There is nothing to support the suspicion that John Ruggles controlled the circumstances of his appointment, the founding of the patent office, and the granting of its first patent, but since that time, nothing has been accomplished as rapidly in Washington.

Among the many things the historians failed to record about John Ruggles was whether or not the invention worked and whether or not it was even tried. The fact that Ruggles returned to his law practice in Thomaston after a single term in the Senate suggests the invention was not a commercial success.

Here's how Ruggles himself described the device in his Patent Number One:

"Be it known that I, John Ruggles, of Thomaston, in the State of Maine, have invented a new and useful improvement or improvements on loco-

motives used on railroads and common roads by which inclined planes or hills may be ascended and heavy loads drawn up the same with more facility and economy than heretofore, and by which the evil effects of frost, ice, snows and mud on the rail causing the wheel to slide are obviated."

The remainder described his design for a "check rail" with notches, to be laid immediately outside the normal rail, which would engage "retreating cogs" mounted outside the wheel. These cogs could be moved in and out to either engage or disengage the notches in the "check rail." It could be used, Ruggles' patent said, either going up hill or coming down.

John Ruggles' invention went downhill, all the way to oblivion, and the "Father of the Patent Office" has been virtually forgotten. He came close, with his "traction wheels" to inventing the cog railway, but somebody else got the credit — and the cash — for that.

maine's

railroad historian

Over the past twenty years, Dick Dole has become all too familiar with century-old Maine newspapers, musty Railroad Commission reports and legislative documents, faded, hand-me-down correspondence, and the lack of light and heat in the basements and back rooms of town libraries from Eastport to South Portland.

And in the process, the retired Maine Central chief mechanical officer has become an authority — perhaps the leading authority — on the railroad history of Maine.

He has read the daily and weekly papers published in Maine since shortly after its statehood began, and has found and recorded thousands of facts that, when pulled together, tell a fascinating tale. The story revealed by the names, dates and deeds of the early Maine railroaders is a worthy chapter — along with the record of the lumber barons, the loggers, the shipbuilders, captains and crewmen — in the history of our state and its industrial and social development.

Dick Dole has unearthed these forgotten facts in many years of determined research, first as a hobbyist in his leisure time, and now as a full-fledged historian, devoting his retirement "working days" to a task that he finds fascinating but endless.

"One thing," he explains, "leads to another." He began his research with the idea of putting together a detailed roster of Maine Central's steam locomotives, something that didn't exist, and for which less ambitious rail history buffs were asking almost daily. This single project has served as the nucleus of all his other research: Maine Central's progenitor railroads, their equipment, personnel and schedules; Maine Central's acquisitions, abandonments, summer hotels, ferries and passenger steamships, terminals, and stations. The search for facts about one revealed hints of another, and Dick was often led not astray, exactly, but off on a side trip into a whole, new area of railroad development.

One result has been a corporate history of Maine Central that is being augmented on a continuing basis by Dick's research. Another is a "Chronology of Maine Steam Railroads and

Related Activities, 1832-1979," now a valuable, basic resource of the Maine Historical Society. Other projects — all by-products of his primary research — have resulted in articles published in *Down East*, *Maine Life*, other popular magazines, and the journals of various railroad and locomotive historical groups.

Dick Dole has been a railroadman since 1925 when he was hired by the Boston and Maine to file tracings in the Mechanical Department at the old North Station. He had studied mechanical engineering at Boston and Lowell Institutes and at Cambridge evening schools, and he advanced in the department quickly through posts as a tracer, then as a designing draftsman. The Depression then brought a low tide in his career and 38 cents an hour as a laborer in the Concord Shops. Dick recalls the hard times, the daily commuting from Haverhill in a Model A Ford, and that once, when he hit a pheasant, the Doles ate it.

With the turn in the economic tide, Dick resumed his climb in the B&M Mechanical Department, appointed first as a mechanic's helper at 53 cents, then a mechanic at 71 cents, then assistant engineer of car design, then assistant to the mechanical engineer of both the Boston and Maine and Maine Central Railroads. He served successively as general foreman, Rigby Car Shop, assistant shop superintendent, Waterville, and mechanical engineer, Maine Central Railroad and Portland Terminal Companies. He succeeded Roy Baker as chief mechanical officer in 1966 and retired in 1971.

But he's still a railroadman, and his frequent trips to the Maine Historical Society library in downtown Portland yield a steady flow of little-known data about equipment, facilities, personnel and accomplishments of Maine's early railroads. He adds his nuggets of new information to the

Historian . . . to Page 10



Richard F. Dole, retired Maine Central chief mechanical officer, for many years a serious researcher and railroad historian, searches old newspapers for facts in the files of the Maine Historical Society in Portland.

growing collection in his manuscripts. He also shares with friends of similar interests, or swaps information with other researchers — if they're serious, and if they send a "SASE" — a self-addressed, stamped envelope.

Dick's respect for facts and historical detail is well-known to fellow members of the Maine Historical Society and the world-wide Railway and Locomotive Historical Society. He is also a past president and honorary member of the New England Railroad Club and a past member of several AAR mechanical division committees.

Maine railroad history is a full-time job for Dick now, with no salary, of course, but he's glad he has it. He feels he's still accomplishing — still doing something of use and value to his peers and the railroad people who'll follow him, and still adding material of historical value to the written record of his adopted state.

But as he says, the job is never done. After twenty years and countless hours in back rooms of country libraries, after searching through hundreds of dusty volumes and brittle, yellowing newspaper files, the Maine Central Steam Locomotive Roster — the project that started it all — is, he says, "only 99.99 per cent complete."

et cetera

Railroad editors are passing a story around these days about Southern Pacific's runaway locomotives. It seems that a while ago the two, coupled together, took off on their own. A yard foreman and another railroader chased them in a pickup truck for 20 miles, then shot them with a 12-gauge.

Yup . . . he shot off the air hoses, and the units went into an emergency stop.

We understand the hoses have been replaced, but the two locomotives refuse to move during the hunting season.

So does Boston & Maine's wreckmaster "Bub" Beaudoin, who was working last fall near Wakefield, N.H., when, as they used to say in the dime novels, "two shots rang out."

One creased his arm and the other smashed the key hanging on his belt. "Bub" and the rest of the crew hit the dirt. When a hunter appeared, asking what they'd done with "his deer," Bub explained . . . rather loudly and clearly.

A notice on the side of blueprint copying machine in the Maine Central's Engineering Department has been appreciated by many General Office railroaders. It was written in the style of Dave Morrah, a Maine lad who made quite a success of his

German dialect stories on the Postscript pages of the old Saturday Evening Post. Making its point in high Teutonic style, the note goes like this: "Achtung!

"Das machine is nicht fur gerfing-erpicken und mittengrabben. Ist easy schnappen der springenwerk, blowenfusen und poppencorken mit spitzen-sparken. Ist nicht fur gewerken by das dumkopfen. Das rubbernecken, sightseeren keeppen hands in der pockets, relaxen and watchen der blinken-lights."

Heartiest congratulations to members of the 470 Railroad Club on their 25th anniversary. Membership continues to increase . . . up 100 since 1975. Neils Johnson, clerk-treasurer, reports that the group held ten regular meetings in 1979 with an average attendance of 48. A highlight of the new year was a ladies' night and annual banquet at the Red Jacket in North Conway, March 29. A trip on Dwight Smith's Conway Scenic Railway was a part of the program.

Of Paper Mills . . . from Page 3

All are tremendous investments and significant contributions to the industrial future of their communities and state, but at \$254 million, the expansion at Rumford is the most extensive. It will modernize the big, former Oxford Paper Company mill and increase its daily production by 40 per cent to some 1,400 tons.

Whether intended or not, Rumford's Boise-Cascade mill, expanded and modernized with new product and new responsibilities, is a monument to Hugh J. Chisholm of Portland, mentioned in the companion editorial. Chisholm founded not only Oxford, but International Paper Company and was a long-term director, shareholder and dominant leader and advisor to Maine Central.

Chisholm was an entrepreneur in the old tradition — self-made, self-possessed and a consistently successful developer of natural and human resources. He knew paper mills and he knew railroads, and he completely understood their interdependence. That relationship demonstrates to us that above all else the past and current expansion of Maine's paper industry is clear evidence of the confidence placed in Maine Central and its future by Maine's most important industry.



General Office co-workers recently attended a birthday lunch for Eric P. Smith, assistant treasurer and director, cost analysis. From left, Theresa Slattery, Greg Savage, Jack Coyne, the guest of honor, Colleen Andrews, Shirley Wilson and Henry Sawyer.

news briefs

Railroader Helps Bring Softball Nationals to Waterville

Softball buffs say one in ten Americans plays in the game, and it looks right now as if most of them will be in Waterville August 21-24 for the National Modified Pitch Softball Tournament.



This snow's got to go, says John Larracey.

There's a Maine Central Railroadman deeply involved in the plan-making. John Larracey, retired Waterville Shops machinist and Commissioner of Capitol District, Amateur Softball Association, helped lure the tournament to Waterville.

John and three other Central Maine Softball leaders waged a successful campaign, with some high-powered help, to have the Elm City selected as the site over Port Huron, Michigan, Morristown, Tennessee, and Spokane, Washington.

The selection was made in Anaheim, California, several weeks ago by the American Softball Association Commissioner's Council after three balloting sessions and great pressure from the backers of all four prospective tournament cities. Waterville's help came from Mayor Paul LaVerdiere, Recreation Director Fred LaLiberty, Councilman Lester Giguere, State Senator Dick Pierce, Governor Joe Brennan and Senators Bill Cohen and Ed Muskie. Their support, and that of the Maine Publicity Bureau, was relayed vigorously in Anaheim by John Makowski, another Waterville area softball big-wig.

John Larracey said the tournament, to be played simultaneously on the three local diamonds, is expected to bring 35 to 40 teams to Waterville, each with a retinue of coaches, trainers, relatives and fans. He said members of the local softball team that leads the Elm City Softball League on July 31 will be hosts for the event.

Director A. Peck Dies in California

Alfred Peck, a Maine Central director from 1946 to 1979 passed away in Berkeley, California, on April 3.

During the forties Mr. Peck and his associate, the late James Maitland, gradually acquired enough Maine Central stock to effect working control of the railroad. Believing in the Company's future and that the stock (some of which was acquired as low as \$5 per share) could be "worth something." They arranged the election of E. Spencer Miller as president in 1952 and with a view to elimination of management by Boston and Maine.

In 1965 Mr. Peck sold over 20,000 shares to Amoskeag Co. at \$122.50 per share while some stock was acquired by Mr. Miller and some remained with Mr. Peck who continued as a director until forced to resign by failing health in 1979.

Director Peck was a friend to many Maine Central people. His constructive influence, particularly in the big refunding of 1953, played an important role in the security of all employees and the development of the prosperity of the Company.

Mr. Peck never married and is survived by a brother, Robert Charles Peck and his son, both of whom attended the funeral services with Rev. Garvey McLean officiating which were held in Portland on April 10 with interment in Evergreen Cemetery. Mr. Peck will be missed and forever revered by his railroad friends.

Freeman Named Safety Supervisor

The appointment of Arlan E. Freeman, Jr., as safety supervisor, has been announced by Arnold J. Travis, executive vice president. Freeman succeeds Edward D. Galvin in the post.

Freeman joined Maine Central in 1969 as a clerk-crew dispatcher at the enginehouse in Bangor. He was appointed assistant to the road foreman-engines in 1974 and road foreman — engines in 1978. He was educated in Iowa State University and the University of Maine.

25-Year Service Pins

The following Maine Central and Portland Terminal Company employees qualify for 25-year service awards during the first six months of 1980:

V. E. Fehlau	Secretary	Portland
E. R. DeGrasse	Conductor	Bangor
V. C. Tardiff	Conductor	Waterville
L. H. Bujold	Conductor	Waterville
C. Q. Heskett	Clerk	Portland
G. P. Conley	Clerk	Portland
J. E. Lancaster	Asst. Engineer Structures	Portland
R. G. Esty	Valuation Statistician	Portland
C. E. Cooper	Painter	Cooper's Mills

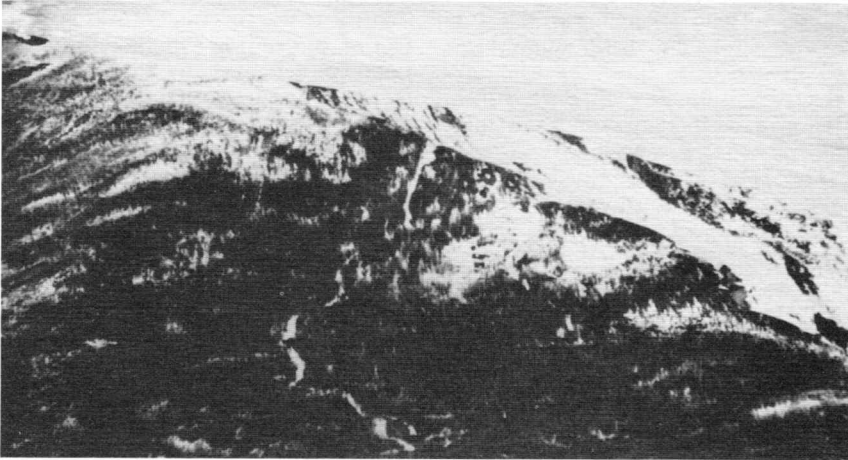

Eugene Wakefield and wife Helen, shown at the base of the Headwall, Tuckerman's Ravine, Mount Washington, made the lower photo from the top of the Headwall, showing the long and steep slope of packed snow in which they've just cut steps (extreme lower right) and climbed. The Wakefields' winter hobby is the most demanding and spectacular of any revealed in a recent physical activity survey of General Office railroaders.

Activity Survey Finds Snow Climbers

Eleanor True, an assistant editor, had a pretty good idea of how her physical activity survey of the General Office Building would turn out.

She expected fellow workers to list swimming, cross-country skiing, golf, running, biking, tennis, hiking, bowling, downhill skiing and sailing. Almost everyone, her returns indicate, enjoys one or more of these sports.

But would you believe square dancing? Okay...how about ballet?

Eleanor's questionnaire revealed both are favorite activities of a few persons, and that weight lifting and karate have their disciples, too.

Jim Landry, Revenue Office, lifts weights one to two hours daily, five days a week. Eugene Banks, a spare operator, lifts weights, too, and continues his daily workouts with karate.

The questionnaire returned by Eugene Wakefield, Chief Dispatcher's Office, was the big surprise. He

and wife Helen are into one of this area's newest and most daring winter sports, snow climbing. Armed with ice axes and wearing crampons — kingsize creepers with ten or a dozen sharp points — the Wakefields cut steps in the wind-packed snow of Tuckerman's Ravine and other terrifying trails and walk up — and hopefully, walk down — Mount Washington.

They say it's easier when there's snow than it is when rocks and loose gravel make the trails treacherous and difficult. "It's like walking up a long flight of stairs," they say.

And for those who don't exercise because they feel it's too late, consider Larry Reinsborough. Larry retired from the Disbursements Office in 1976. A year ago, he had a complete checkup and enrolled in the Lifeline running program at Yarmouth. He's jogging three miles now, three mornings a week.

Galvin Appointed

John E. Hamilton, manager, personnel and labor relations, has announced the appointment of Edward D. Galvin, former safety supervisor, as assistant to manager-personnel and labor relations.

Galvin, who has served as safety supervisor since 1975, is a graduate of Boston University. He began his railroad career as a management trainee with the Chessie System in 1967. He later served as a senior analyst on industrial development for that railroad. He came to Maine in 1970 as assistant director, Maine Department of Commerce and Industry. He joined Maine Central in 1974 as director of public relations and editor of the MESSENGER.

Peterson Promoted

Edward R. Peterson, Jr. has been promoted to the position of road foreman — engines. He became a brakeman in 1962 and a locomotive engineer in 1971. He was appointed to the position of assistant road foreman — engines in 1979.

Stanley Appointed

George H. Stanley has been appointed regional manager — sales and service. He began his railroad career in the Accounting Department in 1956 and progressed to the position of credit manager. He is a 1950 graduate of the Boston School of Mechanical Dentistry.



The Grapevine

General Offices

St. Valentine's Season ran true to form with wedding bells ringing for Fred A. Bither, Car Accounting, when he and Marion O'Brien of South Portland were married on February 16th. We all wish them a happy future! To make the occasion even more memorable, the first snowstorm of an almost snowless winter occurred on the day of the wedding. Marion and Fred had a wonderful wedding trip to Florida, and enjoyed the summer weather in winter, except once when winter came there, too. Among the various Maine people they saw while in Florida were Mr. and Mrs. Walter Allen. Walter was with Maine Central for many years.

Margaret and Arthur Murdock, Disbursements, enjoyed a family reunion with their five children and their families and five grandchildren in Florida. The entire family group boarded an AMTRAK train



Arthur and Margaret Murdock and friend at Disney World.

out of Boston in good weather the first week in March. The snow began when they reached Washington, D.C., and by the time they reached Georgia, they ran into a full fledged blizzard and were held up in reaching their final destination by quite a few hours, an ironical switch this winter! Needless to say, Disney World was the big hit for the youngsters, but they also enjoyed Busch Gardens, Sea World, etc. And last, but not least, the real novelty today of a train trip!

Pat Lowery of car service and her husband, Jim, an engineer, returned from a March skiing vacation at Sugarloaf Mountain with smiles on their faces and no broken bones. During a record "no snow-fall" winter, their timing couldn't have been better! Sugarloaf received over two feet of snow during that time, and Jim and Pat had the best skiing of the season.

Car distributor Duke Lazette and wife Diane spent their February vacation visiting their daughter Karen in Bartlett, N.H. They had an enjoyable time cross-country skiing, also known as "skinny skiing" which is not to be confused with "skinny dipping."

Ralph Libby of car service and his wife Ardith traveled to Bermuda March 10th enjoying the warmer climate and unique environment of the island. They left the moped riding to the more adventurous and



Elizabeth T. Goodie, daughter of Joyce and "Dick" Goodie, Auditor Revenue Department, will be graduated from Deering High School this Spring. She will attend the University of Maine at Orono in September.

used the buses and ferry boats to sightsee, shop and relax.

Vivian Lawrence, wife of signal testman Philip Lawrence, was awarded 19 ribbons at last year's Cumberland Fair. She entered 21 items which included crochet, needlepoint, afghans, a quilt, a pillow, stuffed animals and canned preserves! When Vivian is not busy working on a new project, she is employed at the Shaw's store in Falmouth.

Congratulations to circuit designer Art Cunningham and his wife on the birth of their son, Kyle, on April 7th. They also have two daughters, Myriah 3, and Dawn who is 9.



Finishing up her first year in olympic gymnastics is Danielle Duplessie, daughter of Walter and Sonia Duplessie, Auditor Revenue Department. She enjoyed the floor exercises tremendously, but she would like to find some way to eliminate the aches and bruises that are so much a part of the routines.

Former signalman Scott L. Lentz, son of signal engineer Philip Lentz and his wife Glenda, has recently been promoted to Signal Design Engineer at Thomas K. Dyer, Inc., an engineering consulting firm in Lexington, Massachusetts.

Our deepest sympathy to Ralph Libby,

car service, on the loss of his father, Virgil G. Libby, who died March 31st in an Auburn nursing home at the age of 84. Condolences also to Ralph's wife, Ardith, who lost her mother, Mrs. Earle W. Frank, on February 28th after a brief illness in a local hospital at the age of 85.

Marty Walker, Revenue Office, is dusting off her "track" shoes again. This time she's off for a two-day excursion on the Bangor & Aroostook Railroad from Northern Maine Junction to Caribou, Presque Isle and other points. The trip, co-sponsored by the 470 Club, is the first passenger travel on the BAR since 1961.

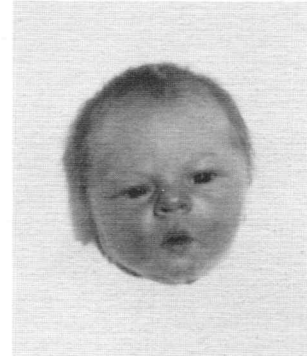

Jonathan H. Maxwell, son of John Maxwell, machine operator, and wife Loretta, was a New Year's baby, born Jan. 7. His dad, injured in a hunting accident last fall, expressed his thanks for the thoughts and gifts of fellow workers during his recovery.

Scorecard

The Couples' Bowling League ended its bowling season on April 10 with the winners of the first half Team 4, Lydia and Bill White and Mary and Burt Davis, bowling off against the winners of the Second Half Team 3, Bonnie and Arlan Freeman and Pat and Jerry Shea. The Banquet was held on April 19th at the Merry Manor in South Portland.

As the Men's Bowling League draws to a close, Team 6 with Fred Bither, Don Anderson, Bob Casey, and Bob McLain clinched the number one spot for the second half and will bowl for top honors against the first half winners Team 1, Bob Marston, Ken Strout, Bob Prevost, and John Foster on Monday April 14 which should prove to be a very interesting contest. The following scores have been set and are final for the 1979-1980 bowling season: High Team Single is held by Team 6, Fred Bither, Don Anderson, Bob Casey, and Bob McLain with a fine score of 452. High Team Total goes to Team 4, Mike Hansen, Steve Marston, Craig Wilson and Skip Ramsdell, who on the last night of regular bowling set the record with a score of 1271. High Average is held by John Foster with a potent 111. High Individual Single is shared by John Foster and Al Dyer with scores of 149 each. High Indi-

vidual Three also goes to John Foster with an outstanding 390. The next closest was Bob McLain with 387 and Craig Wilson with 375. Some of the other high averages in the League this year were Skip Ramsdell with 109, Al Dyer with 107, Bob Miller with 103, Bob McLain with 103 and Don Andrews with 102. This season's commissioners, Steve Marston and Craig Wilson, wish to thank everyone who participated in this year's Men's League for making it the great success it was.

The Maine Central Railroad Golf League will start on or about May 7 and will be headed this year by commissioners Ralph Gordon and Al Bowen. Highlights of the Annual Bowling Tournament and of the golf season will be given in the next issue of the Messenger.

To the friends and fellow workers of the late Gene Harjula:

Mrs. Janice Harjula wishes to extend her thanks and appreciation for the cards, flowers, and gift of money she received. The money was enough so that the Harjula family will use it for a head stone with the hope it will be ready for Memorial Day. A special thanks is extended to Mr. Wendell Lewis, agent—Rockland, for all his help and support in their desperate time of need.

To the friends of Tate Cummings:

Tate wishes to thank everyone for the gift of money that he received while he was sick. Tate is up and around now and everyone here is glad to see him back to work.

Retirees

Both Eddie Westcott and Amy are enjoying retirement. He retired 10 years ago as Manager, Car Utilization, and she retired in 1968 after many years in the President's Office and Operating Department. They live at 51 Garrison Street, Portland. Ed is a member of the "60 Plus Club" in Woodfords, is a hunter in the Fall, and a gardener in the summer. Amy is a member of the Woman's Literary Union, and is looking forward to her flower garden this Spring.

George Silva, retired superintendent of locomotive maintenance, and wife Ruth, also have plenty to do. He retired eight years ago, is a member of the "60 Plus Club," and the "Old Railroad Wheels" a group of B&M retired employees, who meet once a month in Lynnfield, Mass. George is an avid fisherman, and they are looking forward to a mobile home this summer at Thompson's Point, Sebago Lake. They live at 6 Groves Street, Portland, Maine.



Jim Small, known as "Smallie", retired P.T. Co. Electrician, and Mary, of Cornish, Me. It was a Happy Birthday in many ways for Mary, who became 'of age' and can receive her Annuity.



Messenger assistant editors gathered for a meeting in Portland in March to discuss their important role in the publication. From left to right: Brad Peters, editor, Alice Foley, Edith Young, Connie Davis, Alice, Allen, Molly Fehlau, Lucette Huard, David Smith, Sonia Duplessie, Geoffrey Doughty, Eleanor True, Charlie Redstone, Mary Morse and Wendell Lewis.



Frank E. Garland III, left, chief clerk, Rigby Engine House, Portland Terminal Company, was presented with a 35-year membership pin recently by BRAC local chairman John D. Murray.

Ruth Christiansen, retired secretary, General Manager's Office, 12 years ago, lives at 310 Eastern Promenade. Ruth is seeing the world with her sisters-in-law, along with a Shrine Group. Last Fall they visited many places in the Mediterranean, including Greece, Jerusalem, Rome, Yugoslavia, London, by a ship cruise on the "Navarino" for two weeks. She recently returned after visiting the Virgin Islands. She still plays her full keyboard organ at home, and played for her church for 40 years.

One of the most popular bosses in the Engineering Department was Ray Jackson, who retired as division engineer five years ago. Wife Bertha retired from Waynflete School at the same time. Since then the grass hasn't grown under their feet, as they have driven to California and back twice. In 1975 they travelled via the Trans-Canada Highway, stopping at Two Harbors, Minn. to visit daughter Natalie and family, then on to Lake Louise and San Francisco and Los Angeles where they visited daughter Judy. Returning to Punta Gorda, Florida, via San Diego and New Orleans, they decided to build a home in the sun in 1976. He'll attend his 50th Class Reunion in July, and his 78th Infantry Division Reunion in

Knoxville, Tennessee. They live at Highland Lake, Maine, in the summer, and other times at 770 Malaya Court North, Punta Gorda, Florida 33950. Son Larry is working as machine operator for Portland Terminal Company.

Who's the most popular man in town? Tate Cummings, of course! We dropped into the Hospital to see Tate, who was in there for a kidney operation, and he looked great! Mrs. Cummings was there, and other folks were coming right, left, and sideways. Says he's doing fine. Can't keep a good man down for long.

A lot of folks are interested in what their friends and former fellow employees are doing now, and their addresses. Please write a note or call Mary E. Morse, 12 Riggs Street, Portland, Maine 04102, Telephone 772-1654 and we'll let them know.

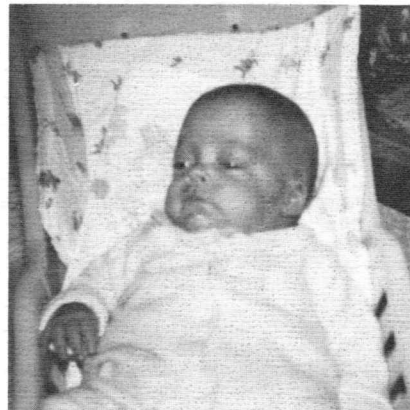

This is Donna Marie Bilodeau, who now weighs 11 pounds, having gained nine pounds and eleven ounces (that's right, her birthweight was 1 pound, five ounces) and who is doing just great after an extra-early arrival and long stretch in the Neonatal Intensive Care Unit at MMC. She is the daughter of Susan and Richard Bilodeau of West Buxton and the grand-daughter of Conductor and Mrs. Stanley Mattatall.



Vivian Lawrence and her prizewinning handiwork.

Waterville Yard

Burns Hillman, yardmaster, at present is spending his vacation in Florida. He keeps sending post cards and not saying anything about meeting old friends, etc. Occasionally, he'll mention the weather and kinda rub it in a little. He keeps saying plenty about the sights, such as an old song of his, "Standing on the corner, watching all the girls go by."

Bill Welch, retired conductor, also was in Florida recently and this was told to us by a fellow worker. Bill was looking up an old friend of his, a 90-year-old retired conductor he used to work with many years ago. Bill called his house and the wife answered, "At present he's not in the house." So Bill, not wanting to impose said he would call later. The wife said to wait a couple of minutes and she would get him down from the roof so he could talk to his old buddy. This friend was no other than Harry Gibbs, who now makes his home in Florida. Can you imagine that—90 years old and still full of pep and vinegar!! Harry Gibbs' last job, from what I heard, was on the Skowhegan Branch when we had passenger service on that branch.

The family of Joe Boudreau, conductor, Waterville Yard, — all 11 children — were present for this picture taken on Joe's birthday, August 11, 1979, and also the day of his daughter's wedding. From right to left — Daniel, a sophomore at Waterville High School; Donald, a junior at Waterville High; James, a senior at University of Delaware; David, a senior at Waterville High School; Julie, a freshman at Waterville High; Joe, father of the group, Jeanne (the new bride), and mother, Theresa; Susan, a sixth grader; Mark, operating a paint business; Jerry, a senior at North Adams State College; Paul, in Man Power Training and Development at Scott Paper in Winslow; and Ronald, employed at Colby College.

Our condolences are in order for another of our great losses. I regret to say that our good friend and co-worker Ralph La-Liberte, 1st trick yardmaster retired, recently passed away. I know he'll be missed by all. Ralph was an avid sportsman. He hunted and fished with many a co-worker, and in his spare time, you could also see him at the Lewiston Fairground trying his luck. Occasionally, when downtown, he



Joyce Begin, daughter of Cornelius and Dorothy Begin, clerk in Waterville Engineering Department, will be graduated June 26 from Central Maine Medical Center, Lewiston, and will be employed at Mid-Maine Medical Center, Waterville.

would visit the people at the freight and yard offices.

Another co-worker, also convalescing, is "Bow" Congdon, brakeman. His misfortune is his ankle. We don't see him hopping along as he's from Sidney way, and he needs his car to get around. We don't know the seriousness of his injury, but we all hope it won't be long before he shows up for work. Good luck "Bow" and hurry back.

Another Florida vacationer was Roland Cook, brakeman. He and his wife "Bev," chief clerk in the Freight Office, spent their vacation taking in the Florida sunshine. They also brought back souvenirs—Roland eats those sunshine oranges like they were going out of style. Someone said, "I don't blame him, they are good."

We don't hear too much from "Cliff" Dunn, 1st trick operator, Tower A, who spent the best part of the winter in Florida, laughing at all of us here in Waterville Yard. We'll have our turn come good weather. We'll stop in to say hello while he sweats it out at Tower A.

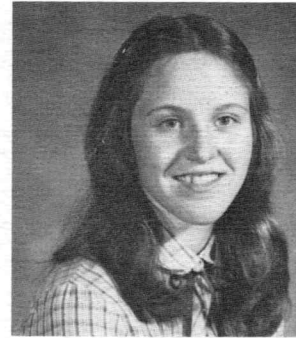

Donna Begin, the daughter of Cornelius and Dorothy Begin, Waterville, was tapped for the National Honor Society at Winslow High School in March. She is a junior and a varsity cheerleader and has been nominated for Girl's State in June.

Our condolences to "Dick" Choate, whose father passed away recently. Dick's father was also a former railroad employee. He was retired from crossing tender off Main Street Crossing. I am sure he'll be missed by many friends who used to stop in to say hello to him at the crossing a few years ago.

Now, fellow employees, you can breathe at ease—you don't have to worry about plowing snow in the yard this year. Spring is in season, and that means nothing but relaxation from snowstorms. Just watch for



mud spots and holes and dream of the good summer weather to come.

Another employee convalescing from surgery is Lucien "Donat" LeFebvre, brakeman, Conductor N.J. Vigue's right hand man. Donat is anxious to get back also. We're pulling for you, Donat. Hurry and get well. Our best wishes for a quick recovery.

Arthur Genest, conductor, is also convalescing. We understand he'll be back real soon. Let's hope so. Best wishes to Arthur.

Jeffery Mason, son of Mr. & Mrs. Conrad Mason of Augusta, recently won two trophies at the State YMCA Swim Championships held at the University of Maine in Orono. Jeff, who swims on the Kennebec Valley YMCA Swim Team, was on the winning 100-yard medley prep boys relay team and swims the back stroke. The relay team was unbeaten during the season. The 10 year old also won 4th place in the State in the 100-yard individual medley. In addition to his swimming, the 5th grader enjoys Boy Scout activities, volleyball and fishing. Jeff's dad holds second trick Bill Rack at Waterville.

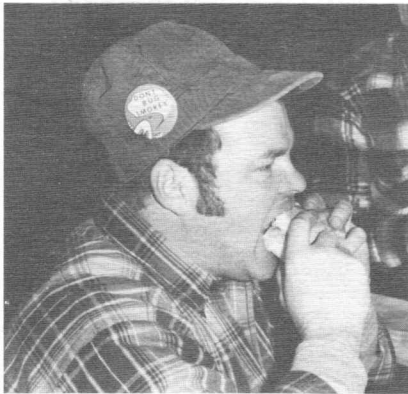

His badge says "Don't bug Smokey," so we won't, except to mention that the Waterville switching crew member has a summer place at Lake Moxie, likes his outdoor fireplace, his camera, his CB radio, his pipe and ham sandwiches.



Bob Mahon, brakeman, Waterville Yard, is a volunteer fireman and a member of the Town Budget Committee at Carmel. He raises cattle, too, and has very few idle moments.



Susan M. Snow, daughter of Ken Snow, car checker, and Elaine Snow, car clerk, Waterville, will be a June graduate at Winslow High School. Susan has been active in the Band, Sports and Student Council. She was class historian her Junior Year and had the lead in the Senior Class Play. She has also been on the Honor Roll. She has been accepted for the Nursing Program at the University of Maine at Presque Isle.

Waterville Shops

John Larracey ended his railroad career May 31, 1978, after serving Maine Central 43 years as a machinist at Waterville Shops. Since that time, he has gotten more involved in civic activities, particularly officiating softball games.

John got started umpiring—first baseball and then softball—after deciding he was too old to continue playing. After becoming a softball umpire six years ago, he became a charter member of the Greater Waterville Softball Umpires Association. John served as president of GWSUA until last year when he resigned that post to become Commissioner of the Capital District, encompassing the Waterville-Augusta area. His duties include registration of teams, supervising of tournament play, periodic meetings to set policy for organizing of umpires and players, and presiding at hearings involving disciplinary action of players. Recently John has been named Deputy State Commissioner, expanding his territory to include all points north of Augusta.

Alden H. Finimore, retired assistant chief mechanical officer, and his wife Gloria, chief clerk at Waterville Shops, have returned from a Caribbean Cruise on Veendam, Holland American Lines, stopping at St. Croix, Martinique, Barbados, and Aruba as Ports of Call.

We hope that Rick Chamberlain enjoyed his two weeks in Florida. Also congratulations to Rick and family on the arrival of their new grandson, Peter, born March 24, 1980.

Paul Getchell visited St. Thomas on his vacation.

Our condolences to the family of Percy Butler, retired machinist, who passed away recently.

Florien J. Warren, watchman from Clinton, Maine, four years ago invented a safety

tool for installing and removing vehicle coil springs. The tool is fitted around a coil spring and adjusted to proper fit, with uprights and with removable pins at top and bottom to hold spring compressed while removing and installing. In January patent number and rights were accepted and issued to Mr. Warren and the tool is now being marketed. Hopefully it will soon be available to mechanics who put the emphasis on safety on the job.

Congratulations to Bob Rines, trackman, and wife Kelley on the arrival of their first daughter in January. The Rines also have three sons. Bob and his wife delivered the baby themselves at their home in Oakland.

Raymond Flynn, retired foreman, received his 25-year pin in March. Ray had never received his service pin through an oversight. Better late than never, Ray!

Bev Cook, chief clerk, and Roland Cook, conductor, became grandparents in March to a granddaughter named Terra Lee. Parents are Terry and Cindy Swift of Gardiner.



Ken Fitton, brakeman, gives Lloyd Powers, conductor, a big Hello at Waterville.

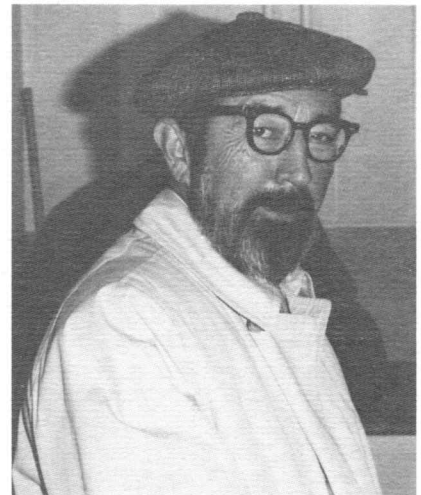

This is none other than Arthur C. P. Lennon, retired assistant superintendent, on his recent visit to the Waterville Yard Office. He now lives in Puerto Rico.

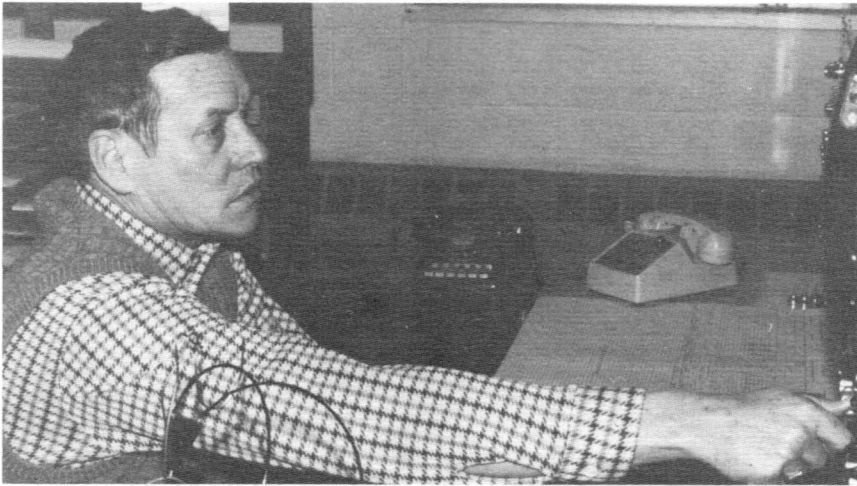

Wally Oakes, operator, Tower A, busy with his panel.

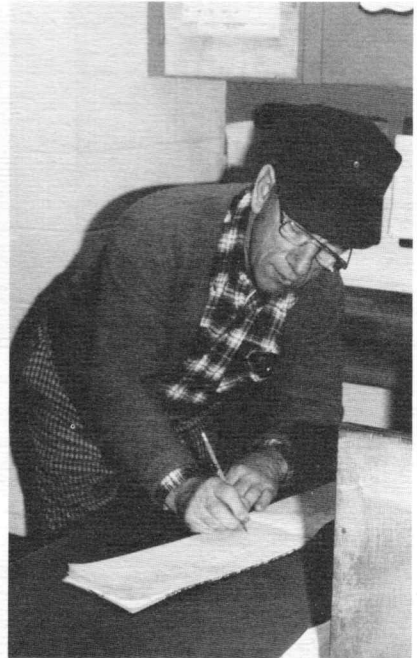

Conductor Leo Bujold checking the train register at Tower A, Waterville Yard.

Eastern Subdivision

Larry Dodge, furloughed trackman, Machias, and wife Beth are proud parents of a baby girl born March 9 at a Machias hospital. Congratulations, Larry and Beth.

Visitors at Machias this past winter were Art Palmer, Charlie Bayrd, Sr. and Ralph Scott.

Signs of changing times when Dennysville agent Howard Brown has to flag down the RFD mail carrier instead of a train to get railroad company mail to Portland.

Big celebration due Dennysville on April 22 when trackman Dick Curtis' cow is due to calve. Section foreman Lew Lyons of Ayers Junction will be on hand to tie a tag on the newborn, designating it as beef, so next time Dick offers him a chunk of beef it won't turn out to be mutton.

According to Dick, Woodland section foreman Dana Brown got a trimming buying next year's beef critter. Seems Dick drove to Canada with Dana to buy some good hay to get the poor critter back on its hooves.

Darold Ames, Lew Lyons, Floyd White, Dana Brown, Grant Ross, Eastern Subdivision section foremen, and Norm Bagley, track repairman, attended a Foremen's Meeting in Bangor.



Aunt Shari and Sarah . . . that's right. Shari is 5, the daughter of Howard and Donna Spencer, and Sarah, 14 months, is the daughter of Christopher Spencer and Howard's grand-daughter. Howard is division crew foreman at Waterville, and son Chris is a trackman.

A real interesting visitor at Dennysville was George Ward, 86 years of age. George worked five years before World War I. He remembered when they picked ice for one whole mile at Dennysville to let the passenger train thru. George still makes wheelbarrows and sleds. He has driven since 1916 without a blemish on his driving record.



Two of Bangor's three last crossing tenders are shown at their post on Front Street. From left, E. Whitehouse and Bill Golden.

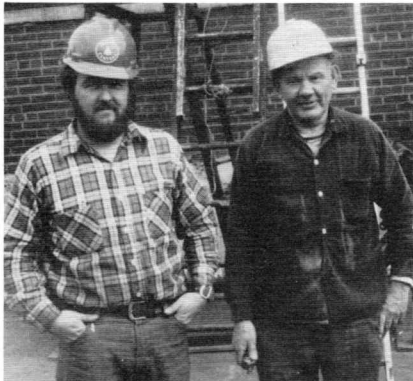

Malcolm Card, left, and Charlie Dobbins, right, B&B Dept., take a minute off from removing storm windows from the Bangor Freight Office. Charlie, quite a gardener, told us not to plant onions next to potatoes because the potatoes will cry their eyes out.



A big cigar, and apparently a big decision, for Jim Young, trackman at Rumford.

Visitors at Ayers Junction this winter were Guy Carter, Arthur McGlaufflin and George Rice.

Heard a version of how Ayers Junction got its name. Seems Harrison Ayer was approaching the crossing with his horse and buggy when the approaching train whistled. The horse bolted and Harrison was banged up in the accident. A railroad representative asked what remuneration he desired. His only request was to name the junction after him.

John Mincher, chief clerk, Bangor Engine House, is recuperating at home following surgery. We hope to see John back at his desk in the near future.

Winnie Carroll, clerk, Engineering Dept. and husband, Ed, have been vacationing in Florida for the past several weeks. We expect to see them back any day now.



Section crew working in Bangor Yard are, left to right: D. Milheron, G. Dorre, D. Stover, G. O'Leary, K. Hodgkins, M. Merritt and D. Jones.

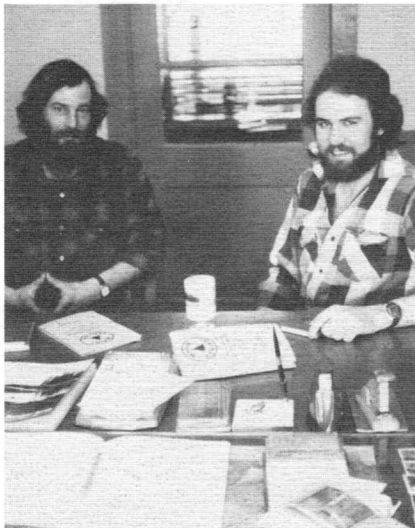

Bob Babski, left, and Gary Michaud, spare brakeman, Bangor, preparing to take their flagman's test.



Cute Jennifer Lynn Corbett was born last October 29th to Bangor trainman John Corbett and wife, Terry. Jennifer's grandfather, Ed Corbett, works at Bangor Car Shop. Congratulations to John and Terry!

Athie Sez

Many thanks to my old railroad buddies as well as newly made friends for the notes and letters that have been sent to me. It is so good to hear from everyone. Keep 'em coming!

Clyde Cooper writes from Spring Hill, Florida about the warm, sunny weather with his lawns and flowers so pretty. Coop also has a navel orange tree in his back yard and in January picked more than a bushel off it. Besides caring for his grounds, he does a little dancing to keep limbered up. Coop doubts if he'll make his annual trip back to Winthrop this summer. For many years, he worked at Winthrop and finally finished out his railroading as a clerk at the Gardiner Freight Shed. Come to think of it, Coop did do some spare work for a while after Gardiner closed down. Good to hear from you, Coop!

Recently received a second letter from Gerald and Mildred Coogins. Gerald worked for many years for Portland Terminal Company. Their grandson, Stephen King, is a signalman. Gerald used to go hunting and fishing down to Tomah Station—"Caught lots of trout and shot quite a few deer." They have a small garden each year and Mildred does some canning.

A couple letters from Walter Furbish were most appreciated. Walt worked in the Signal Department Repair Shop for many years. One of Walt's great loves was a chestnut canoe he and Marjorie journeyed to New Brunswick to pick up.

Bob Gibbs, retired Portland Division conductor, sent along a nice note. He is living in Clinton and been on the "Goof-off" list along with the rest of us for a couple years. Says he lives on Gospel Hill. Don't suppose that's giving him any ideas for a new profession? He doesn't see too many of the old gang, but is close enough to the railroad to hear the trains go by every day. Gosh, Bob, whenever I hear a train whistle for MacGeorge's Crossing, it's a sign of rain! Bob's tour of duty included the Augusta switcher for quite a spell.

Got a nice note also from Nat Tracy, daughter-in-law to Ralph Tracy who passed away a number of years ago. Ralph's son, Phil, works at Tower A, Waterville, and Grandson John is track foreman at Winthrop. When Ralph was agent at Augusta, I well remember him telling of working at Ayers Junction and living in Meddybemps.

How strange my retirement years are spent within twenty-five miles of Ayers Junction.

Talked with Arthur Palmer this past winter over at the Machias station. He has been retired six years from the track department. He enjoys baseball and fishing. Art had a "stay" at the DEC Hospital in Machias recently but was out around and dropped into the Machias station shortly after. He lives in Whitneyville. His four children are scattered from Hampton, New Hampshire to the University of Maine.

Made several visits to retired folks and plan on numerous more contacts before summer.

Howard Wakefield worked forty-two years with a fourteen year stretch on the Unionville section and the last seven years at Franklin. He worked with Earl Dorr's spare crew as Assistant Foreman at intervals. Howard enjoys his work shop where he turns out wishing wells, snowmobile tow sleds and even a chest of drawers. He and his wife, Cassie, enjoy snowmobiling immensely except the past two winters have been zilch account of no snow. They live in Unionville, a couple doors from Vernell Leighton.

Vernell Leighton has a total of thirty-seven years railroad service under his belt. He worked in Carl Foss' crew for a number of years. Seems the "old Indian" crops up in quite a few of the old timers' conversations. Vernell was at the Unionville section under Roy Farren for eighteen years. Vernell, unfortunately, has lost one leg but that doesn't stop him a mite. He can ding around on the substitute like no one's business. I first met Mac Tracy and Vernell around 1944 when their "soup cars" were in back of the old Augusta freight shed on the house track.

Howard "Tubby" Clement lives at Hersey's Point in Pembroke. He originally worked at Eastport as a freight handler for sixteen years and the following ten years at Waterville Stores as a burner. Tubby has been on disability pension the past eight years. He used to commute weekends with Carl Foss who is now B&B foreman at Waterville. Tubby says he is "Chief Cook and Bottle Washer" while wife, Elsie, works each day at Eastport. He is a blessing for the crews of the scallop draggers as he stays tuned in on their CB channel and has "land lined" for their numerous times when the boats have developed engine trouble. Every morning, he gives the full weather report to the fishermen over the CB and is certainly appreciated. Tubby still journeys to Boston each May for his annual checkup.

Say, Sam Ruth, seen any chubby red-heads on ladders lately? Yup! It was this old agitator that mailed the picture to you, surprised!

Malcolm "Mac" Tracy, who worked in Will Russell's stone crew from 1923 until his retirement at sixty-three years of age, has been a resident at Marchalin Nursing Home in Milbridge the past four years. Mac is in good spirits despite a problem with his eyes and a leg condition. What a pleasant hour or more of reminiscing as Mac had worked all over the system and we had many mutual friends. One particular favor he asked was to be remembered to the "old Indian." Carl Foss. He talked of laying a brick platform at both Augusta and Waterville stations in 1923. Recent visitors to see him was Ollie Grant, Vernell Leighton and Howard Wakefield.

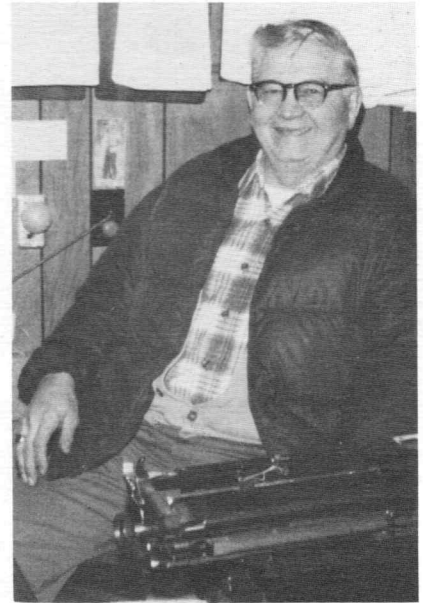

ATHIE'S ACTION DOWN EAST — Athie Bryant was busy with her camera and supplied these pictures of her railroad friends on the Eastern Sub-Division. Top Left, Clayt Stoddard, Pinky Scott, Floyd White, Arthur Palmer and Charlie Dobbins, all at Machias Station. Top Right, Agent Roger Wakefield. Center Left, Embert "Gunner" Tibbetts, retired section foreman, Columbia Falls, and wife Tish. Center Right, Lew Lyons, Bill Sturk, Dick Curtis, Howard Brown and Darold Ames at Dennysville. Right, Howard "Tubby" Clement at Pembroke.

Permit No. 180
Portland, Maine
PAID
U.S. POSTAGE
BULK RATE

H. Bentley Crouch
81 Montvale Rd.
Weston, MA 02193
C11

Public Relations Department
Maine Central Railroad Co.
222 St. John Street
Portland, Maine 04102
Address Corrections Requested

railroad safety

Watch Your Step

Next to traffic accidents, falls kill more people than any other type of accident! More than 13½ million people are injured in falls every year. Many of the falls could have been prevented by:

- 1) Keeping walkways and aisles clear of obstacles which present potential hazard.
 - 2) Keeping floors and walkways free from grease, oil, water, and bare ice.
 - 3) Using extreme caution whenever working on ladders and above floor level.
- Finally, you can keep the odds against accidents in your favor, with your attitudes.



"MY FAVORITE COLORS? BLACK AND BLUE."

Every time anyone drops something on the floor he should see it as an accident waiting for a chance to happen, maybe to him. If he did look at it that way, he'd pick up the object right then and there so that an accident couldn't happen to anybody; he'd put the thing in some safe place. He'd really practice the idea of "A place for everything and everything in its place."

Water, grease, and oil on the floor should be cleaned up immediately. Either use some antislip preparation, or give the area a good old-fashioned scrubbing.

Scrap and waste material should not be allowed to clutter up the floors.

Another place to look for hazards is on stairways. They should be kept free from foreign matter, and nothing should be stored on them. Report treads that need repair and be sure to use hand rails.

Ladder habits are important, too. Falls from ladders cause a lot of injuries, all of which are preventable if ladders are in good condition, fitted with spikes or non-slip bases, and properly placed and braced.

If we are all safety-minded and on the alert to report hazards, we'll be able to eliminate most slips and falls.

And last but not least, try to set a good example — Safety is Contagious.